

LINEA BAR ↙ 450 RANGE

1

EURAST

GRUPO / GROUP / GROUPE / GRUPP



LÍNEA 450BAR / 450 RANGE

G1 PAG.06



G1 PAG.07



G1 PAG.08/11



G1 PAG.12



G1 PAG.16/18



G1 PAG.20/22



G1 PAG.23



G1 PAG.24/25

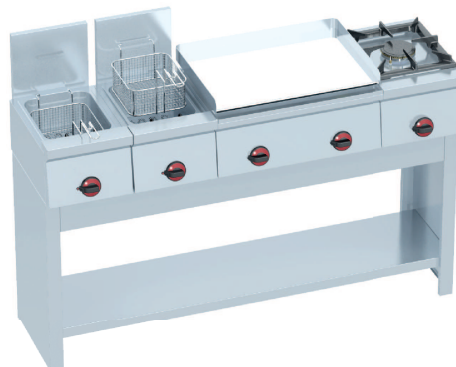

ACCESORIOS / ACCESSORIES / ACCESSORIES / ZUBEHÖR

G1 PAG.26/27



LIGNE 450 / 450 KOLLEKTION



450BAR

CARACTERÍSTICAS

CONSTRUCCIÓN

- En acero inoxidable, interior y exterior.
- Patas regulables en todos los aparatos.

HORNILLOS A GAS

- Grifos de latón, dotados de máximo regulable y mínimo. Con bobina de seguridad y termopar.
- Quemadores desmontables para su limpieza de 4'5Kw. **1**
- Con parrillas de fundición vitrificadas. **2**
- Se pueden substituir por plancha-cubeta de Frankfurt. **3**

HORNILLOS ELÉCTRICOS

- Dotados de conmutador con 3 posiciones y piloto indicador de funcionamiento.
- Con placas redondas de fundición de 2Kw. **4**

PLANCHAS A GAS Y ELÉCTRICAS

- Modelos a gas, con grifos de latón, dotados de máximo regulable y mínimo. Con bobina de seguridad termopar.
- Con quemadores tubulares de acero inoxidable.
- Disponen de mirilla en el frontal.
- Modelos eléctricos con termostato y piloto indicador de funcionamiento.
- Con resistencias blindadas de acero inoxidable, montadas en cajones debidamente aislados.
- Todos los modelos con cajón recoge grasas frontal. **5**

PLANCHAS A GAS SERIE 2

- Con placas de hierro pavonadas de 6mm de espesor, plegadas sin uniones para su máxima higiene. Con desagüe frontal. **6**

PLANCHAS A GAS O ELÉCTRICAS SERIE 5

- Con placas de hierro pavonadas de 10mm de espesor, plegadas sin uniones para su máxima higiene. Con desagüe frontal. **7**

PLANCHAS A GAS O ELÉCTRICAS SERIE 8

- Con placas de cromo duro de 12mm de espesor, rectificadas y con baño de cromo duro de 50 micras. Con peto de acero inoxidable soldado en todo su contorno superior e inferior para su máxima higiene. Con desagüe frontal. **8**
- Se suministran con una espátula cúter para su limpieza, la cual se debe usar sin golpear, sólo deslizando la cuchilla por la encimera. **9**
- La forma de limpieza, es una vez parada y al cabo de 30/45 minutos (aún caliente), se deben colocar cubitos de hielo, los cuales se evaporarán inmediatamente. Entonces la espátula-cúter, deberá pasarse suavemente, para eliminar al máximo la grasa, y seguidamente un paño húmedo. No poner desengrasante hasta el día siguiente antes de poner la plancha en marcha y quedará la superficie brillante como nueva.

CREPERAS A GAS Y ELÉCTRICAS

- Tienen las mismas características que los hornillos a gas o eléctricos.
- Con placas vitrificadas de 10mm espesor y de 380mm de diámetro.

CHARACTERISTICS

MAKING

- In stainless steel, inside and outside.
- Adjustable legs on all appliances.

GAS BOILING TOPS

- Brass taps, equipped with maximum and minimum adjustable. With safety coil and thermocouple.
- Detachable burners for cleaning of 4'5Kw. **1**
- With vitrified cast iron grills. **2**
- Can be replaced by Frankfurt tray-bucket. **3**

ELECTRIC BOILING TOPS

- Equipped with 3-position switch and operating indicator light.
- With round cast iron plates of 2Kw. **4**

GAS AND ELECTRIC HOT PLATES

- Gas models, with brass taps, equipped with maximum and minimum adjustable. With safety coil and thermocouple
- With Tubular stainless Steel burner
- They have a peephole in the front.
- Electric models with thermostat and pilot operating indicator.
- With stainless steel armored resistors, mounted in separate drawers.
- All models with frontal fat drawer. **5**

GAS HOTPLATES SERIE 2

- With 6mm thick iron plates, folded without joints for maximum hygiene. With frontal drain. **6**

GAS OR ELECTRIC HOTPLATES SERIE 5

- With 10mm thick iron plates, folded without joints for maximum hygiene. With frontal drain. **7**

GAS OR ELECTRIC HOTPLATES SERIES 8

- With hard chrome plates of 12mm thickness, rectified and with hard chrome bath of 50 microns. With stainless steel breastplate welded in all its upper and lower contour for maximum hygiene. With frontal drain. **8**
- Supplied with a cutter spatula for cleaning, which should be used without hitting, just sliding the blade across the countertop. **9**
- The cleaning method is once stopped and after 30/45 minutes (still hot), ice cubes must be placed, which will evaporate immediately. Then the spatula-cutter, should be passed smoothly, to remove the fat as much as possible, and then a wet cloth Do not put degreaser until the next day before putting the iron on and the surface will remain shiny as new.

GAS AND ELECTRIC CREPES MACHINES

- With the same characteristics as gas boiling top or electric small cookers
- With 10mm thick vitrified plates and 380mm diameter.



1



2



3

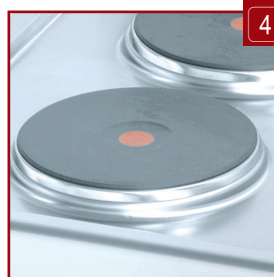

4



5





CARACTÉRISTIQUES

FABRICATION

- En acier inoxydable, intérieur et extérieur.
- Pieds réglables sur tous les appareils.

RÉCHAUD À GAZ

- Robinets en laiton, équipés de maximum et minimum réglable. Avec bobine de sécurité et thermocouple.
- Brûleurs détachables pour le nettoyage de 4'5Kw. 1
- Avec des grilles en fonte vitrifiées. 2
- Peut être remplacé par un bac à seau de Francfort. 3

RÉCHAUD ÉLECTRIQUES

- Équipé d'un commutateur à 3 positions et d'un voyant de fonctionnement.
- Avec des plaques rondes en fonte de 2Kw. 4

PLAQUES À GAZ ET ÉLECTRIQUES

- Modèles à gaz avec des robinets en laiton, équipés de maximum et minimum réglable. Avec bobine de sécurité et thermocouple.
- Brûleur tubulaire en acier inoxydable.
- Ils ont un judas à l'avant.
- Modèles électriques avec thermostat et indicateur de fonctionnement de la veilleuse.
- Avec des résistances blindées en acier inoxydable, montées dans des tiroirs correctement isolés.
- Tous les modèles avec tiroir à graisse avant. 5

PLAQUES À GAZ SÉRIE 2

- Avec des plaques de fer de 6 mm d'épaisseur, pliées sans joints pour une hygiène maximale. Avec drain avant. 6

PLAQUES À GAZ OU ÉLECTRIQUES SÉRIE 5

- Avec des plaques de fer de 10 mm d'épaisseur, pliées sans joints pour une hygiène maximale. Avec drain avant. 7

PLAQUES À GAZ OU ÉLECTRIQUES SÉRIE 8

- Avec des plaques de chrome dur de 12 mm d'épaisseur, rectifiées et avec un bain de chrome dur de 50 microns. Avec une cuirasse en acier inoxydable soudée dans tous ses contours supérieur et inférieur pour une hygiène maximale. Avec drain frontal. 8
- Fourni avec une spatule pour le nettoyage, il convient de l'utiliser sans frapper, en glissant simplement la lame vers le bas du comptoir. 9
- La méthode de nettoyage est, une fois arrêtée la plaque, et après 30/45 minutes (encore chaude), il faut placer des glaçons qui s'évaporent immédiatement. Ensuite, il faut passer doucement le coupe-spatule pour éliminer la graisse autant que possible, puis un chiffon humide. Ne mettez pas de dégraissant avant le lendemain avant de poser le fer et la surface restera brillante à l'état neuf.

MACHINES À CRÊPES À GAZ ET ÉLECTRIQUES

- Elles ont les mêmes caractéristiques que les réchauds à gaz ou électriques.
- Avec des plaques vitrifiées de 10 mm d'épaisseur et de 380 mm de diamètre

EIGENSCHAFTEN

BAUWEISE

- Aus Edelstahl, innen und außen
- Verstellbare Füße auf allen Geräten

GASOFEN

- Messingwasserhahn, ausgestattet mit einstellbarem Maximum und Minimum. Mit Sicherheitsspule und Thermoelement.
- Abnehmbare 4, 5 KW Brenner zur Reinigung. 1
- Mit verglasten Gusseisengittern. 2
- Ersetzbar durch Plattenbehälter Frankfurt. 3

ELEKTRO-OFEN

- Ausgestattet mit Schalter mit 3 Positionen und Betriebsanzeigeleuchte.
- Mit 2KW runden Gusseisenplatten. 4

GAS- UND ELEKTROHERD

- Gasmodelle, mit Messingarmaturen, ausgestattet mit einstellbarem Maximum und Minimum. Mit Thermoelement-Sicherheitsspule
- Mit Edelstahl-Rohrbrennern
- Mit Guckloch auf der Vorderseite
- Elektrische Modelle mit Thermostat und Betriebsanzeigeleuchte
- Mit gepanzerten Widerständen aus Edelstahl, die in entsprechend isolierten Schubladen montiert sind.
- Alle Modelle sind mit vorderer Fettschublade ausgestattet. 5

GASHERD SERIE 2

- Mit gebläuten Eisenplatten 6 mm dick, gefaltet ohne Nähte für maximale Hygiene. Mit Frontablass. 6

GAS-ODER ELEKTROHERDE SERIE 5

- Der Rest der Platten mit gebläuten Eisenplatten von 10 mm Dicke, gefaltet ohne Verschraubungen für maximale Hygiene. Mit Frontablass. 7

GAS-ODER ELEKTROHERD SERIE 8

- Ausgestattet mit 12 mm starken, geschliffenen Hartchromplatten und 50 Mikron Hartchrombad. Mit in allen oberen und unteren Konturen verschweißtem Edelstahlschutz für maximale Hygiene. Mit Frontabfluss. 8
- Sie werden mit einem Reinigungsschaber geliefert, der ohne Stoßbewegungen verwendet werden sollte, indem die Klinge sanft über die Arbeitsplatte geschoben wird. 9
- Reinigung: 30/45 Minuten nach der Verwendung (noch heiß) sollten Eiswürfel hineingelegt werden, die sofort verdunsten. Danach mit dem Schaber vorsichtig reinigen, um so viel Fett wie möglich zu entfernen, dann ein feuchtes Tuch verwenden. Tragen Sie den Entfetter erst am nächsten Tag vor Beginn des Grillen auf und die Oberfläche wird wie neu glänzend sein.

GAS-UND ELEKTRO CRÊPE-MAKER

- Sie haben die gleichen Eigenschaften wie Gas- oder Elektroherde.
- Mit verglasten Platten mit einer Dicke von 10 mm und einem Durchmesser von 380 mm

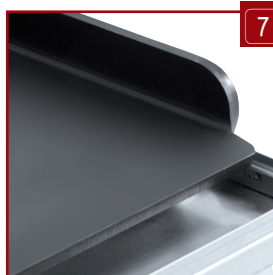
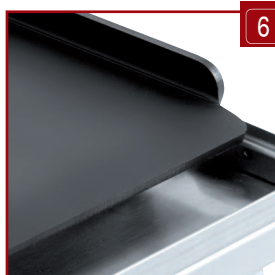

HORNILLOS A GAS

☑ GAS BOILING TOP ☑ RÉCHAUD À GAZ ☑ GAS-KOCHFLÄCHE



450BAR

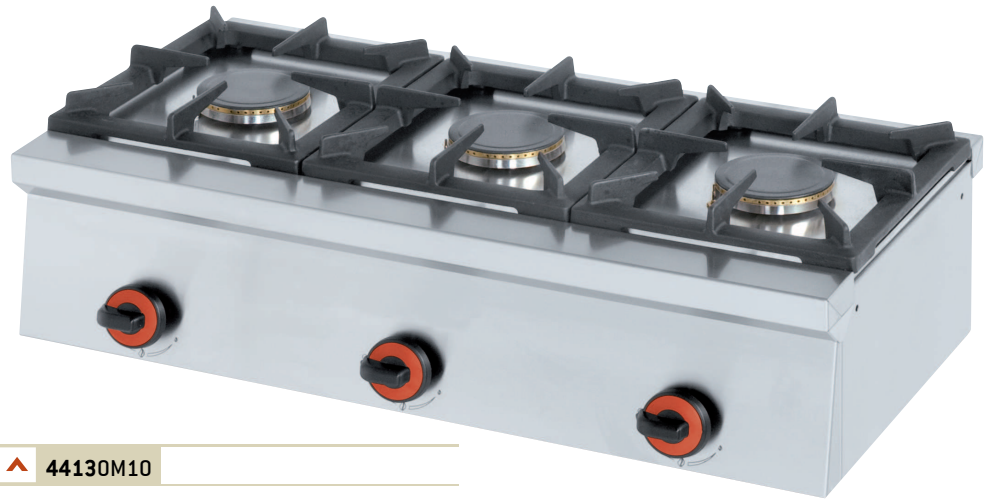

▲ 44130M10



▲ 44110M10



▲ 44120M10 + 44900G10



MOD./COD.						€
44110M10		12	300x450x240	1 x 4,5 Kw	4,5 Kw	390
44120M10		22	600x450x240	2 x 4,5 Kw	9 Kw	680
44130M10		31	900x450x240	3 x 4,5 Kw	13,5 Kw	910





44820M10



44810M10



44830M10

MOD./COD.						€
44810M10		10	300x450x240	1 x 2 Kw	2 Kw - 230/1V	370
44820M10		15	600x450x240	2 x 2 Kw	4 Kw - 230/1V	570
44830M10		22	900x450x240	3 x 2 Kw	6 Kw - 230/1V	790





450BAR



Fe 6 m/m **SERIE 2**



Fe 10 m/m **SERIE 5**



▲ 44250M10



▲ 44050M10



▲ 44240M10



▲ 44040M10



▲ 44230M10



▲ 44030M10



▲ 44220M10



▲ 44020M10



Cr.D 12 m/m

SERIE 8

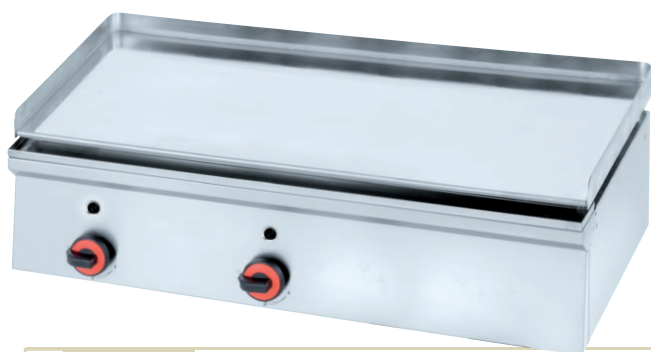

▲ 44450M10



▲ 44440M10



▲ 44430M10



▲ 44420M10

		400x450x240	600x450x240	800x450x240	1000x450x240
		3,5 Kw	7 Kw	14 Kw	17,5 Kw
		400x420	600x420	800x420	1000x420
Fe 6 m/m		16	28	41	54
	MOD./COD.	44220M10	44230M10	44240M10	44250M10
	€	460	560	650	785
Fe 10 m/m		19	32	45	58
	MOD./COD.	44020M10	44030M10	44040M10	44050M10
	€	530	630	725	870
Cr.D 12 m/m		21	34	47	60
	MOD./COD.	44420M10	44430M10	44440M10	44450M10
	€	780	990	1215	1430



450BAR



▲ 4405EM10



▲ 4404EM10



Fe 10 m/m **SERIE 5**



Cr.D 12 m/m **SERIE 8**



▲ 4444EM10

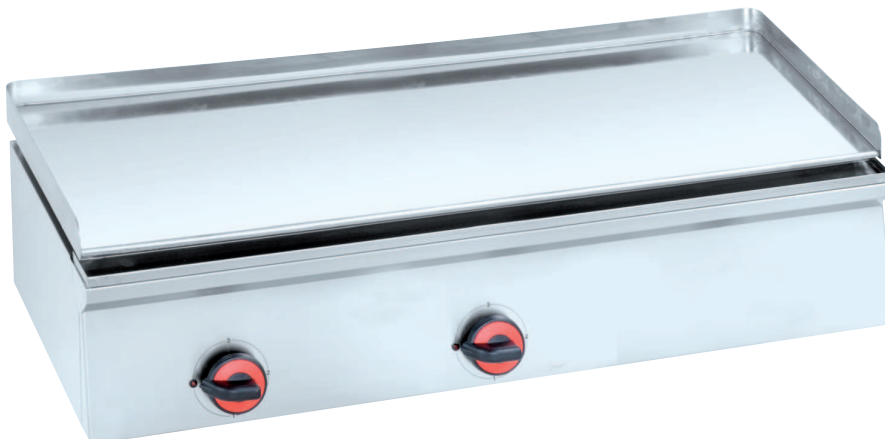

▲ 4445EM10





▲ 4403EM10



▲ 4402EM10



▲ 4443EM10



▲ 4442EM10

		400x450x240	600x450x240	800x450x240	1000x450x240
		2 Kw - 230/1V	3 Kw - 230/1V	4 Kw - 230/1V	5 Kw - 230/1V
		400x420	600x420	800x420	1000x420
Fe 10 m/m		19	32	45	58
	MOD./COD.	4402EM10	4403EM10	4404EM10	4405EM10
	€	530	630	725	870
Cr.D 12 m/m		21	34	47	60
	MOD./COD.	4442EM10	4443EM10	4444EM10	4445EM10
	€	780	990	1.215	1.430

450BAR



▲ 44170M10



▲ 44160M10



▲ 44190M10



▲ 44180M10

MOD./COD.					Ø 380		€
44160M10			20	400x450x240	1 mm x 4,5 Kw	4,5 Kw	530
44170M10			38	800x450x240	2 mm x 4,5 Kw	9 Kw	820
44180M10			20	400x450x240	1 mm x 2 Kw	2 Kw - 230/1V	530
44190M10			38	800x450x240	2 mm x 2 Kw	4 Kw - 230/1V	820



450BAR

CARACTERÍSTICAS

CONSTRUCCIÓN

- En acero inoxidable, interior y exterior.
- Patas regulables en todos los aparatos, excepto los soportes.

BARBACOAS A GAS

- Funcionamiento mediante quemadores tubulares de acero inoxidable que calientan la lava volcánica, que se halla situada encima de una rejilla-soporte. Al calentar la piedra volcánica, hace la función de brasa.
- Con grifos de latón, dotados de máximo regulable y mínimo. Con bobina de seguridad termopar.
- Disponen de mirilla en el frontal.
- Equipan parrillas, siempre de acero inoxidable, de 400, 600 o 900mm según modelo, y con un diseño en forma de teja, que evita que caiga el aceite de los alimentos encima de la lava volcánica, evitando incendios.
- Con un sistema que permite la colocación de la parrilla en dos posiciones, utilizando para ello las asas de baquelita de la propia parrilla. **1**
- Todos los modelos con cajón recoge grasas frontal. **2**

WOK A GAS

- Con grifo de latón, dotado de máximo regulable, mínimo y posición piloto. Con bobina de seguridad y termopar.
- Quemador de fundición de hierro, desmontable para su limpieza de 12Kw.
- Con corona de latón. **3**
- Con parrilla redonda de fundición vitrificada extraíble.

FREIDORAS ELÉCTRICAS

- Con los mandos situados en el frontal para evitar quemaduras
- Cabezal con la resistencia de acero inoxidable y mecanismos, extraíble para su limpieza. **4**
- Con termostato y piloto indicador de funcionamiento.
- Con termostato de seguridad que pára la freidora en caso de aumento anormal de la temperatura del aceite.
- Con cubeta GN de 1/3-5 litros, 1/2-8 litros y 2/3-12 litros según modelo, extraíble para el vaciado del aceite y su limpieza.
- Todos los modelos con cestas de acero inoxidable y tapa.

CONSERVADORES DE FRITO ELÉCTRICO

- Equipa 1 cuba GN 2/3-150 con doble fondo perforado y curvado, para facilitar la recogida de fritos, todo ello extraíble para su limpieza.
- Con una resistencia aleteada debajo de la cuba, para proporcionar calor seco y otra en la pantalla superior de cerámica.
- Con mandos independientes, un termostato para la cuba con piloto indicador y un interruptor-piloto para la pantalla.

BAÑOS MARÍA SECOS ELÉCTRICOS

- Con la cuba GN 2/3-150 en dotación extraíble e intercambiable
- Con una resistencia aleteada debajo de la cuba para proporcionar calor seco.
- Dotado de termostato y piloto de funcionamiento.
- OPCIONALMENTE, disponemos de cubetas GN, 1/3 (cabrían 2 unidades) ó 1/6 (cabrían 4 unidades)

MESAS DE APOYO Y FREGADEROS

- Las mesas o módulo neutro permiten trabajar en la encimera, en lugares con poco espacio.
- Los fregaderos con cuba encastrada a la encimera y grifo monomando. Asimismo, con válvula de desagüe.

SOPORTES ABIERTOS O CON PUERTAS

- Dichos soportes están fabricados para colocar encima de ellos los elementos de cocción formando un conjunto y facilitando la limpieza.
- A dichos soportes se pueden colocar estantes intermedios.
- También pueden usarse para colocar la bombona de butano, colocando el estante, en la posición inferior. **5**
- Asimismo, disponemos de estantes abatibles para colocar en los laterales de soporte. **6**

CHARACTERISTICS

MAKING

- In stainless steel, inside and outside.
- Adjustable legs on all appliances, except the supports.

GAS BARBECUES

- Operation using stainless steel tubular burners that heat the volcanic lava, which is located on top of a support grid. When heating the volcanic stone, it acts as an ember.
- Gas models, with brass taps, equipped with maximum and minimum adjustable. With safety coil and thermocouple
- They have a peephole in the front.
- Equipped grills, always made of stainless steel, 400, 600 or 900 mm depending on the model, and with a tile-shaped design, which prevents the oil from falling onto the volcanic lava, avoiding fires.
- With a system that allows the placement of the grill in two positions, using the bakelite handles of the grill itself. **1**
- All models with frontal fat drawer. **2**

GAS WOK

- Gas models, with brass taps, equipped with maximum and minimum adjustable. With safety coil and thermocouple
- 12kw iron casting burner, removable for cleaning.
- With cast iron crown. **3**
- With round grill made of removable vitrified cast iron.

ELECTRIC FRYERS

- With the controls located on the front to avoid burns
- Head with stainless steel resistance and mechanisms, removable for cleaning. **4**
- With thermostat and pilot operating indicator.
- With safety thermostat that stops the fryer in case of anomalous increase in oil temperature.
- With GN tray of 1 / 3-5 liters, 1 / 2-8 liters and 2 / 3-12 liters depending on model, removable for draining and cleaning the oil.
- All models with stainless steel baskets and cover.

ELECTRIC FRIED CONSERVATORS

- Equipped with a GN 2 / 3-150 tank with double perforated and curved bottom, to facilitate the collection of fried foods, all removable for cleaning.
- With a resistance finned under the tub, to provide dry heat and another in the ceramic top screen.
- With independent controls, a thermostat for the tank with pilot light and a pilot-switch for the screen.

ELECTRIC DRY BAIN MARIES

- With tank GN 2 / 3-150 in removable and interchangeable equipment
- With a resistance flared under the tank to provide dry heat.
- Equipped with thermostat and operating pilot.
- OPTIONALLY, we have GN trays, 1/3 (would fit 2 units) and 1/6 (would fit 4 units)

SUPPORT TABLES AND SINKS

- The tables or neutral module allow work on the countertop, in places with little space.
- Sinks with tub embedded to the worktop and mixer tap. Also, with drain valve.

NEUTRAL SUPPORTS OR WITH DOORS

- These supports are manufactured to place the cooking elements on top of them forming a set and facilitating cleaning.
- Intermediate shelves or doors can be placed on these supports.
- They can also be used to place the butane bottle, placing the shelf, in the lower position. **5**
- Also, we have folding flaps to place on the support sides. **6**





CARACTÉRISTIQUES

FABRICATION

- En acier inoxydable, intérieur et extérieur.
- Pieds réglables sur tous les appareils, sauf les supports.

BARBECUES À GAZ

- Utilisation de brûleurs tubulaires en acier inoxydable chauffant la lave volcanique située sur une grille de support. Lors du chauffage de la pierre volcanique, il s'agit comme une braise.
- Robinets en laiton, équipés de maximum et minimum réglable. Avec bobine de sécurité et thermocouple.
- Ils ont un judas à l'avant.
- Grilles équipées, toujours en acier inoxydable, suivant le modèle, de 400, 600 ou 900 mm, avec un design en forme de tuile qui empêche le pétrole de tomber sur la lave volcanique en évitant les incendies.
- Avec un système qui permet le placement du grill dans deux positions, en utilisant les poignées en bakélite du grill lui-même. **1**
- Tous les modèles équipés d'un tiroir pour la récupération de la graisse avant. **2**

WOK À GAZ

- Robinet en laiton, équipé de maximum et minimum réglable. Avec bobine de sécurité et thermocouple.
- Brûleur en fonte, amovible pour le nettoyage de 12Kw.
- Avec couronne de laiton. **3**
- Avec grille ronde en fonte vitrifiée amovible.

FRITEUSES ÉLECTRIQUES

- Avec les commandes situées à l'avant pour éviter les brûlures
- Tête avec résistance en acier inoxydable et mécanismes, amovible pour le nettoyage. **4**
- Avec thermostat et indicateur de fonctionnement de la veilleuse.
- Avec thermostat de sécurité qui arrête la friteuse en cas d'augmentation anormale de la température de l'huile.
- Avec bac GN de 1 / 3-5 litres, 1 / 2-8 litres et 2 / 3-12 litres selon le modèle, amovible pour vidanger et nettoyer l'huile.
- Tous les modèles avec paniers et couvercle en acier inoxydable.

RÉSERVES POUR FRITES ÉLECTRIQUES

- Equipé d'1 réservoir GN 2 / 3-150 avec fond double perforé et incurvé pour faciliter la collecte des aliments frits, tous amovibles pour le nettoyage.
- Avec une résistance pliée sous le réservoir, pour fournir de la chaleur sèche et une autre dans l'écran supérieur en céramique.
- Avec commandes indépendantes, un thermostat pour le réservoir avec pilote indicateur et un interrupteur pilote pour l'écran.

BAIN MARIE SÈCHES ÉLECTRIQUES

- Avec réservoir GN 2 / 3-150 en équipement amovible et interchangeable
- Avec une résistance pliée sous le réservoir, pour fournir de la chaleur sèche.
- Equipé d'un commutateur thermostat et d'un pilote de fonctionnement
- OPTIONNELLEMENT, nous avons des plateaux GN, 1/3 (capacité pour 2 unités) ou 1/6 (capacité pour 4 unités)

TABLES DE SUPPORT ET ÉVIERS

- Les tables ou le module neutre permettent de travailler sur le comptoir, dans des endroits peu encombrants.
- Éviers avec réservoir intégrée au plan de travail et robinet à levier unique. En outre, avec robinet de vidange.

SUPPORTS NEUTRES OU AVEC DES PORTES

- Ces supports sont fabriqués pour placer les éléments de cuisson au-dessus d'eux, formant ainsi un ensemble facilitant le nettoyage.
- Des étagères intermédiaires peuvent être placées sur ces supports.
- Ils peuvent également être utilisés pour placer la bouteille de butane, en plaçant l'étagère en position inférieure. **5**
- Nous avons également des étagères pliants à placer sur les côtés du support. **6**

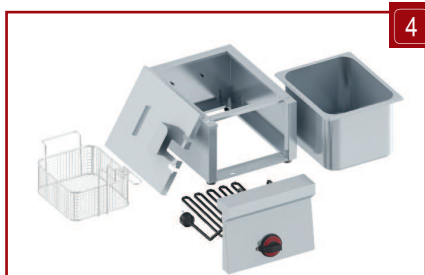

4



5



6

EIGENSCHAFTEN

BAUWEISE

- Aus Edelstahl, innen und außen.
- Verstellbare Füße an allen Geräten außer den Ablagen.

GAS-GRILL

- Betrieb mittels Edelstahl-Rohrbrennern, die die vulkanische Lava, die sich auf einem Gitterträger befindet, erwärmen. Wenn es das vulkanische Gestein erwärmt, wirkt es wie eine Glut.
- Mit Messingarmaturen, ausgestattet mit einstellbarem Maximum und Minimum. Mit Thermoelement und Sicherheitsspule
- Mit einem Guckloch auf der Vorderseite.
- Ausgestattet mit Grills, je nach Modell immer aus Edelstahl, 400, 600 oder 900 mm, und mit einem fliesenförmigen Design, das verhindert, dass Speiseöl auf die vulkanische Lava fällt und Brände verhindert.
- Mit einem System, das das Aufstellen des Grills in zwei Positionen unter Verwendung der Bakelitgriffe des Grills selbst ermöglicht. **1**
- Alle Modelle sind mit vorderer Fettschublade ausgestattet. **2**

GAS-WOK

- Mit Messingarmaturen, ausgestattet mit einstellbarem Maximum und Minimum. Mit Thermoelement und Sicherheitsspule
- 12 KW Brenner aus Gusseisen, abnehmbar für die Reinigung.
- Mit Messingkrone. **3**
- Mit abnehmbarem, verglastem Gusseisen-Rundgrill.

ELEKTRISCHE FRITEUSEN

- Mit den Bedienelementen an der Vorderseite, um Verbrennungen zu vermeiden
- Kopf mit Edelstahlwiderstand und Mechanismen, abnehmbar zur Reinigung. **4**
- Mit Thermostat und Betriebsanzeige.
- Mit Sicherheitsthermostat für die Friteuse, bei ungewöhnlichem Anstieg der Öltemperatur.
- Je nach Modell mit 1/3-5 Liter, 1/2-8 Liter und 2/3-12 Liter GN-Fass, abnehmbar für Ölabblass und Reinigung.
- Alle Modelle mit Edelstahlkörben und Deckel.

ELEKTRO-AUFBEWAHRER VON FRITTIERTEN LEBENSMITTELN

- Ausgestattet mit 1 GN 2/3-150 Tank mit doppelt gelochtem und gebogenem Boden, um das Auffangen von frittierten Lebensmitteln zu erleichtern, alle abnehmbar zur Reinigung.
- Mit einem Rippenwiderstand unter dem Tank, um trockene Wärme zu erzeugen und einen weiteren im oberen Keramikeinsatz.
- Mit unabhängigen Bedienelementen, einem Thermostat für den Tank mit Kontrollleuchte und einem Steuerschalter für die Anzeige.

ELEKTRISCHES WASSERBAD

- Mit einem austauschbaren GN 2/3-150 Tank.
- Mit einem Rippenwiderstand unter dem Tank, um trockene Wärme zu erzeugen.
- Ausgestattet mit Thermostat und Betriebsanzeigeleuchte.
- WAHLWEISE verfügen wir über Tanks GN, 1/3 (für 2 Einheiten) oder 1/6 (für 4 Einheiten).

BEISTELLTISCHE UND SPÜLEN

- Die Tische oder das neutrale Modul ermöglichen das Arbeiten auf der Arbeitsplatte an Orten mit wenig Platz.
- Die Spülbecken haben eine an der Arbeitsplatte angebrachte Spüle und eine einhändige Küchenarmatur. Auch mit Ablassventil.

NEUTRALE ABLAGEN ODER MIT TÜREN

- Elemente, die dazu bestimmt sind, Kochzubehör darauf abzustellen, so dass sie ein Set bilden und die Reinigung erleichtern.
- Auf diesen Ablagen können Zwischenablagen oder Türen platziert werden.
- Sie können auch dazu verwendet werden, in der unteren Position die Butangasflasche unterzubringen. **5**
- Wir haben auch Klappregale, die an den Stützseiten platziert werden können. **6**

6



450BAR



▲ 44710M10



▲ 44720M10



▲ 44730M10



PIEDRA VOLCÁNICA 3KG.

C9500009 € 38

INOX

MOD./COD.							€
44710M10		30	400x450x240	400x400	2 x 3,5 Kw	7 Kw	700
44720M10		38	600x450x240	600x400	3 x 3,5 Kw	10,5 Kw	1.030
44730M10		55	900x450x240	900x400	5 x 3,5 Kw	17,5 Kw	1.375



450BAR

12 Kw

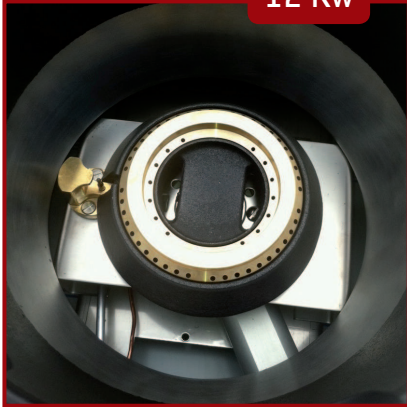

▲ 44370G13

MOD./COD.					€
44370G13		30	400x450x240	12 Kw	990



450BAR



▲ 42880M10

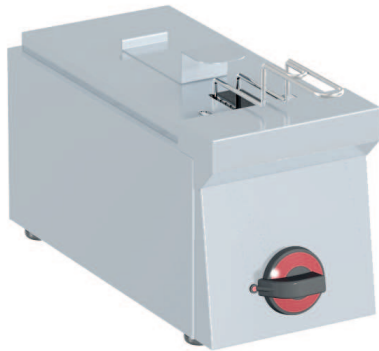

▲ 42050M10

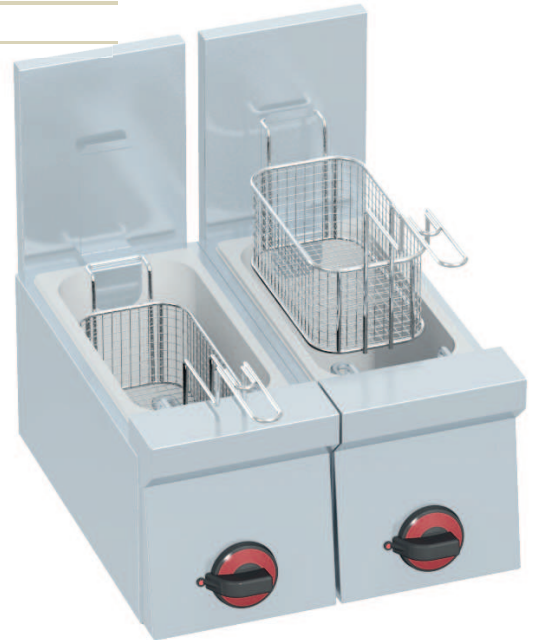

▲ 42550M10

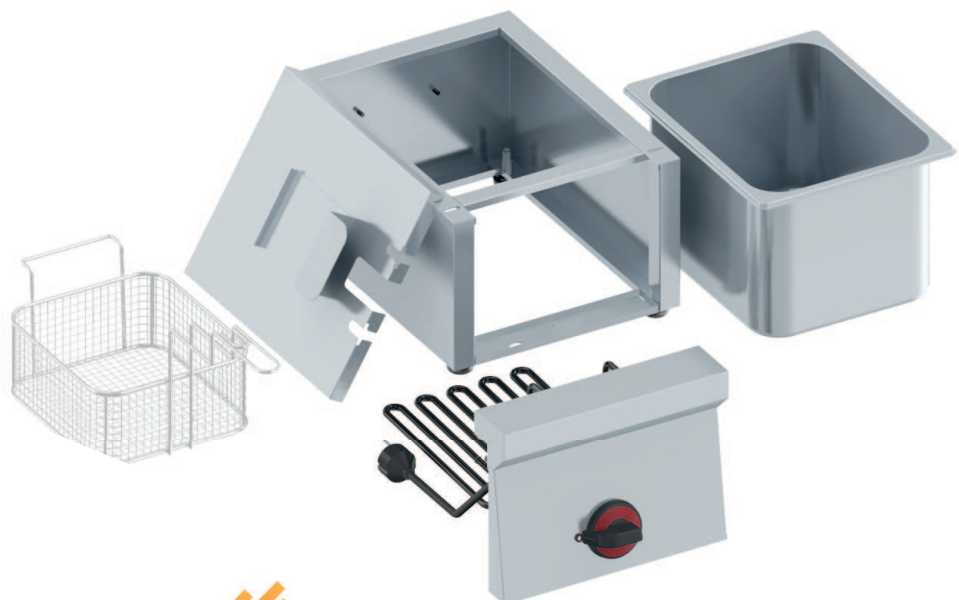



▲ 42080M10



▲ 42120M10

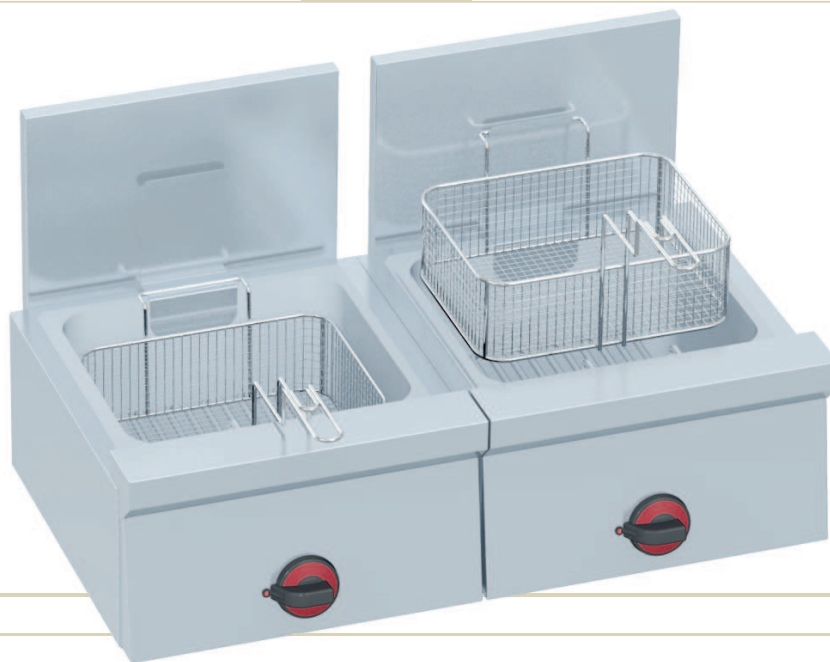

▲ 42240M10

MOD./COD.							€
42050M10		7	200x450x240	176x325x200	5	2,2 Kw - 230/1V	460
42080M10		9	300x450x240	265x325x200	8	3 Kw - 230/1V	530
42120M10		12	400x450x240	352x325x200	12	4,4 Kw - 230/1V	590
42550M10		14	400x450x240	176x325x200	5+5	4,4 Kw - 230/1V	750
42880M10		18	600x450x240	265x325x200	8+8	6 Kw - 230/1V	855
42240M10		24	800x450x240	352x325x200	12+12	8,8 Kw - 230/1V	955
	63930000	-	128x232x100	-	5	-	86
	63920000	-	210x232x100	-	8	-	108
	63940000	-	296x232x100	-	12	-	126

CONSERVA FRITOS, BAÑO MARIA ELÉCTRICOS

ELECTRIC CHIP SCUTTLES, ELECTRIC BAIN MARIES RÉSERVE POUR FRITES ÉLECTRIQUES, BAIN MARIES ÉLECTRIQUES
 ELEKTRO FRITTENWANNEN, ELEKTRO BAIN MARIES



450BAR



▲ 44210M10



▲ 44200M10

MOD./COD.					DOT		€
44210M10		14	400x450x240/450	13 Lts.	GN 2/3 - 150 mm	0,9 Kw - 230/1V	750
44200M10		8	400x450x240	13 Lts.	GN 2/3 - 150 mm	0,5 Kw - 230/1V	540



ENCIMERAS NEUTRAS, FREGADERO, SOPORTES ABIERTOS Y CON PUERTAS

☑ NEUTRAL COUNTERTOPS, SINK, OPEN SUPPORTS AND DOORS ☑ COMPTOIR NEUTRES, ÉVIER, SUPPORTS OUVERTS ET AVEC PORTES ☑ NEUTRAL ARBEISPLATTEN, WASCHECKEN, OFFENE STÜTZEN UND TÜREN

450BAR



▲ 44320M10



▲ 44310M10

MOD./COD.				€
44320M10	8	400x450x240	-	230
44310M10	11	400x450x240/410	DOT	445

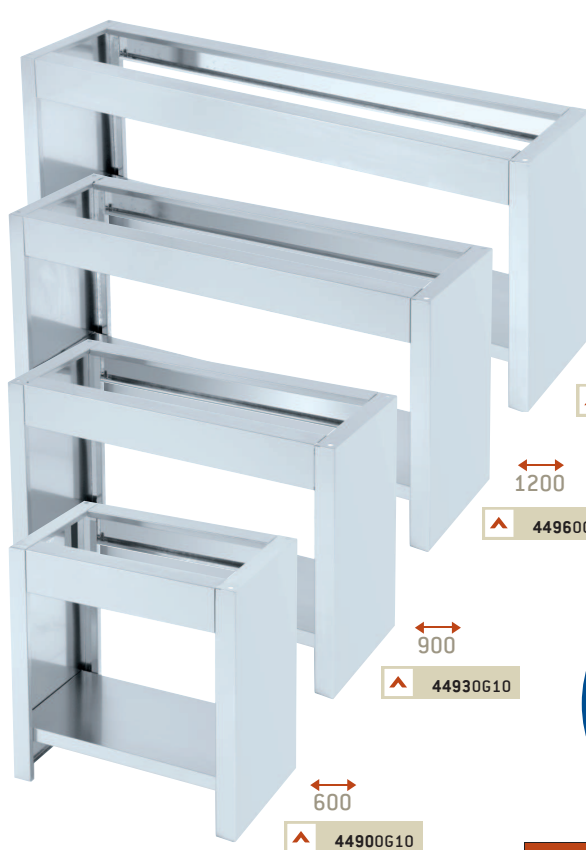

▲ 44990G10

▲ 44960G10

▲ 44930G10

▲ 44900G10



▲ 449305MP

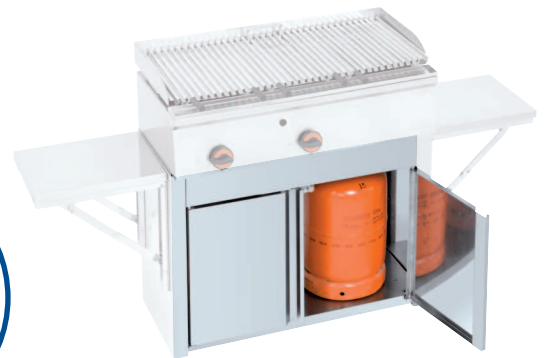

ESTANTE PLEGABLE		
MOD./COD.	DIM.	€
449040M	410x330	105

	SOPORTE ABIERTO OPEN SUPPORTS / SUPPORTS OUVERTS			SOPORTE CON PUERTAS SUPPORTS WITH DOORS / SUPPORTS AVEC PORTES			ESTANTE ADICIONAL ADDITIONAL SHELF / TABLETTE SUPPLÉMENTAIRE		
	MOD./COD.		€	MOD./COD.		€	MOD./COD.		€
600x380x674	44900G10	10	300	449005MP	19	520	449035M	2	90
700x380x674	44910G10	12	310	449105MP	23	540	449135M	2,5	95
800x380x674	44920G10	14	320	449205MP	27	560	449235M	3	100
900x380x674	44930G10	16	330	449305MP	31	580	449335M	3,5	105
1000x380x674	44940G10	18	340	449405MP	35	600	449435M	4	110
1100x380x674	44950G10	20	350	449505MP	39	620	449535M	4,5	115
1200x380x674	44960G10	22	360	449605MP	43	640	449635M	5	120
1300x380x674	44970G10	24	370	449705MP	47	660	449735M	5,5	125
1400x380x674	44980G10	26	380	449805MP	51	680	449835M	6	130
1500x380x674	44990G10	28	390	449905MP	55	700	449935M	6,5	135



CLÁSICO

Conjunto imprescindible en cualquier bar.

Dotado de un plancha de Cromo Duro de 600 mm. y un fuego, de sobremesa.

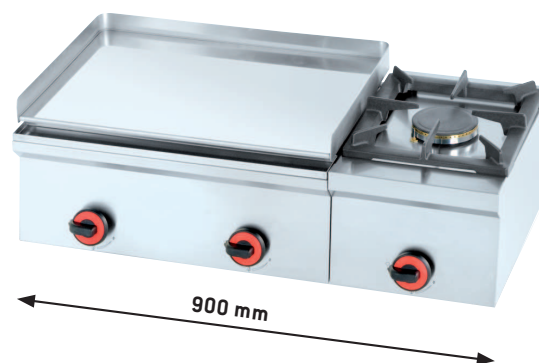

▲ 50500919 🔥

UN POCO DE CADA

Equipo idoneo para el típico bar de pinchos. De carne, de pescado, fritos...

Dotado de barbacoa de 400 mm., plancha de cromo duro de 400 mm, un fuego y freidora, sobre soporte abierto.

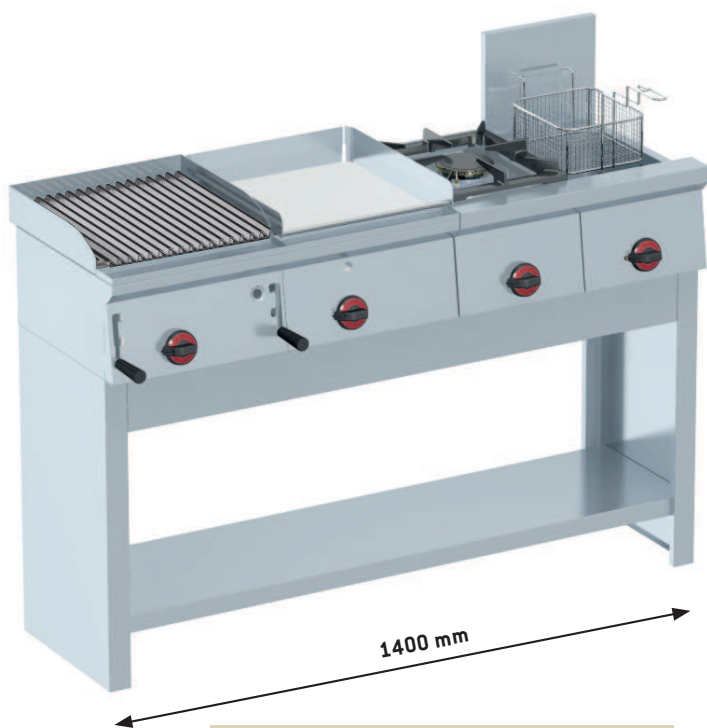

▲ 50600919 🔥 ⚙️



MARISQUERÍA-FREIDURÍA

Conjunto para el bar, cuya especialidad es el pescado.

Dotado de freidora doble, plancha de cromo duro de 600 mm. y un fuego, montado sobre soporte abierto.

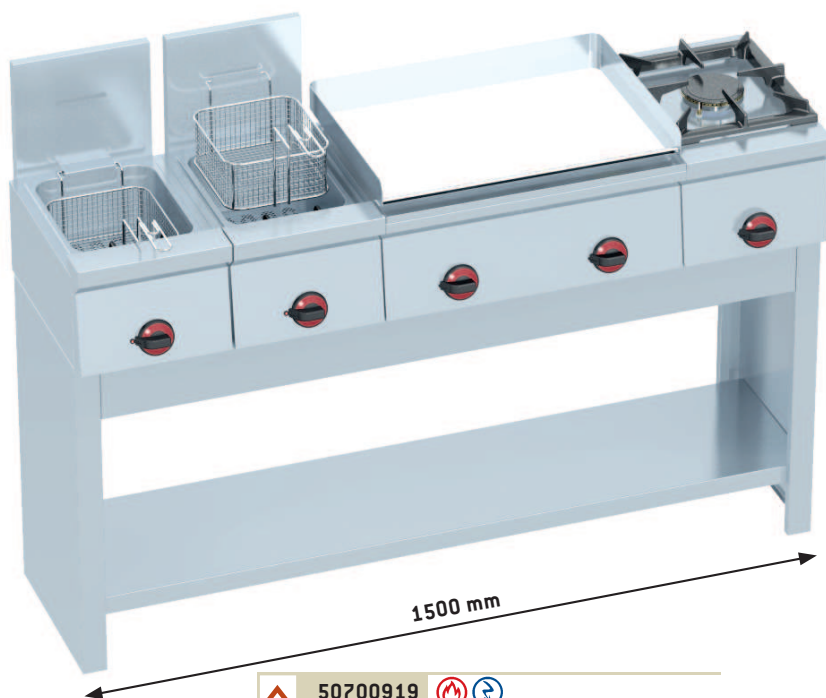

▲ 50700919 🔥 ⚙️



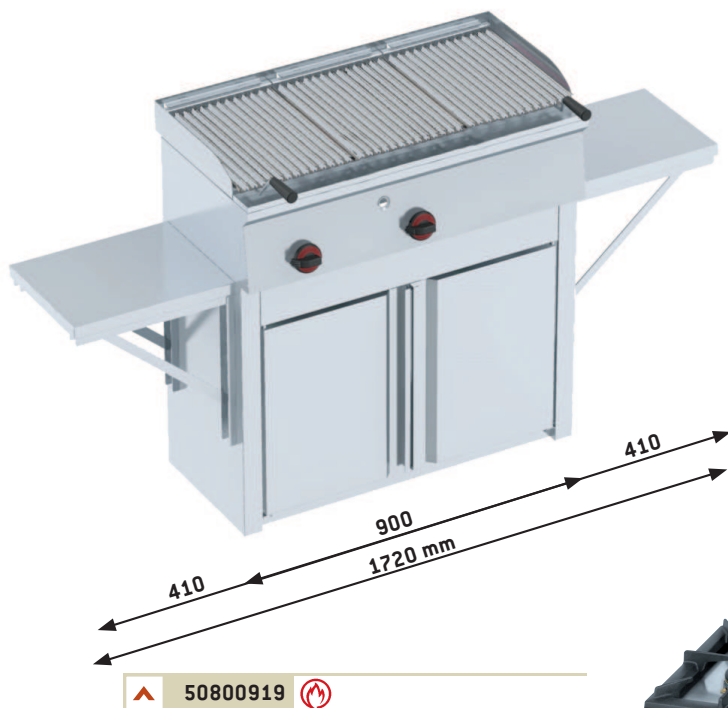

▲ 50800919 🔥

TÍPICO

Para el bar de comidas, que dispone de poco espacio.

Dotado de 2 fuegos y plancha de cromo duro de 600 mm. Sobre soporte abierto.

MUCHA BRASA

Equipo compacto, ideal para bares o terrazas, al aire libre, que deseen ofrecer carnes o pescados a la brasa.

Dotado de gran barbacoa de 900 mm., sobre soporte con puertas, que puede alojar la bombona de butano, con dos estantes plegables, en ambos laterales.

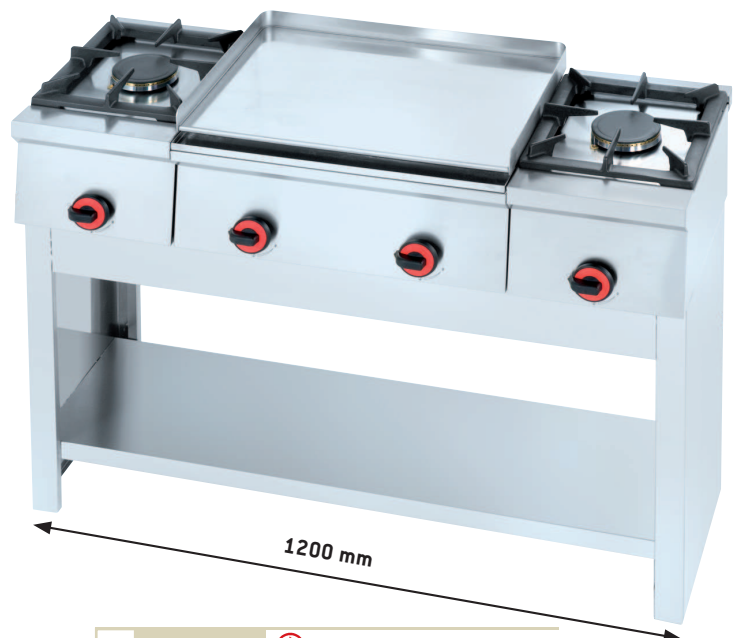

▲ 50900919 🔥

MOD./COD.	🔥	👤	↔ ↗ ↕	PÁGINA	COD. EQUIPOS	⚡	🔥	€
50500919	🔥	46	900x450x240	9 6	44430M10 44110M10	-	11,5 Kw	1.380
50600919	🔥 ⚡	98	1400x450x910	16 9 6 21 23	44710M10 44420M10 44110M10 42080M10 44980G10	3 Kw - 230/1V	15 Kw	2.780
50700919	🔥 ⚡	92	1500x450x910	20 9 6 23	42880M10 44430M10 44110M10 44990G10	6 Kw - 230/1V	11,5 Kw	2.625
50800919	🔥	95	900+820x450x910	17 23 23	44730M10 449305MP 449040M x 2	-	17,5 Kw	2.165
50900919	🔥	80	1200x450x910	6 9 23	44110M10 x 2 44430M10 44960G10	-	16 Kw	2.130

450BAR

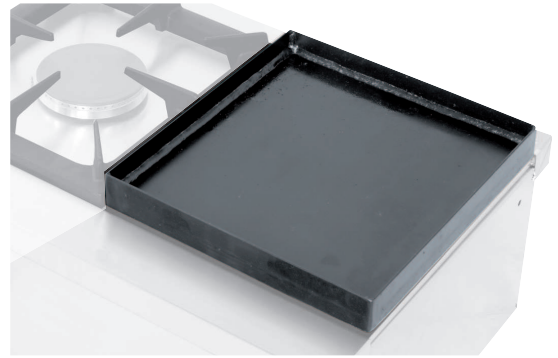

PARRILLAS		
GRILLS / GRILLES		
COD.	↔ ↗	€
C5815349	300 x 335	101

PARA HORNILLOS - CUBETA DE FRANKFURT			
FOR COOKERS - SAUSAGE TRAY		POUR RECHAUDS - CUVETTE POUR SAUCISSE	
COD.	↔ ↗ ↕	€	
3501011P	300 x 335 x 40	127	



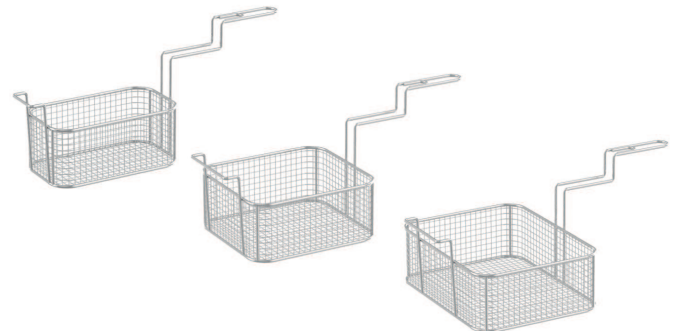
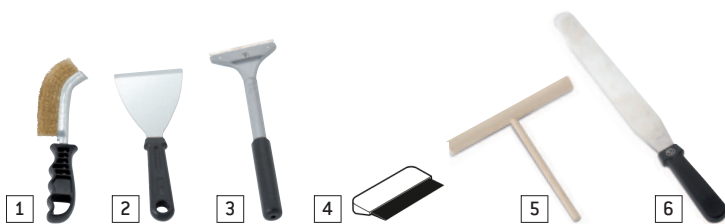

PARA BARBACOA-PARRILLAS		
FOR LAVA STONE GRILLS / POUR GRILLE PIERRE DE LAVE GRILLE		
COD.	↔ ↗	€
447101PX	400 x 400	130
447201PX	600 x 400	170
447301PX	900 x 400	250

PIEDRA VOLCANICA		
LAVASTONE / PIERRE VOLCANIQUE / LAVASTONE		
COD.	📦	€
C9500009	3 KG	38

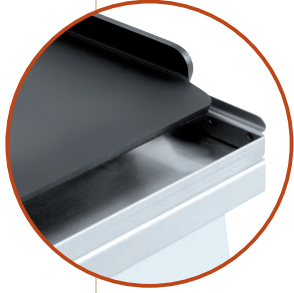

CEPILLO, RASQUETAS Y CREPERAS		
BRUSH, SPATULAS AND PANCAKE / BROSE, SPATULES ET CRÊPES		
COD.	PARA / FOR / POUR	€
96108	1 CEPILLO BARBACOA	29
96107	2 ESPATULA PLANCHA Fe.	15
93085	3 ESPATULA PLANCHA cr.D	25
4A795021	4 KIT 10 CUCHILLAS	25
C4500029	5 CREPERA RODILLO MADERA	6
C4500019	6 CREPERA ESPATULA METALICA	16

CESTAS PARA FREIDORAS			
FRYER BASKETS / PANIER FRITEUSE / FRITEUSE KÖRBE			
COD.	↔ ↗ ↕	📦	€
63930000	128 x 232 x 100	5	86
63920000	220 x 232 x 100	8	108
63940000	306 x 232 x 100	12	126

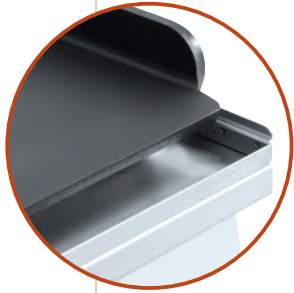
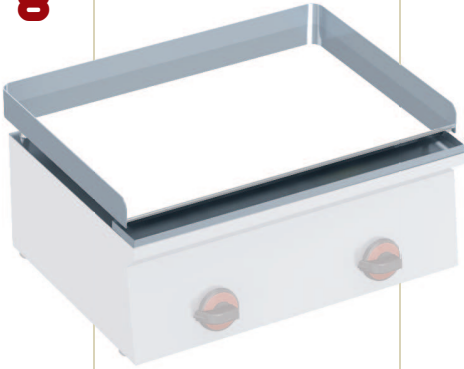
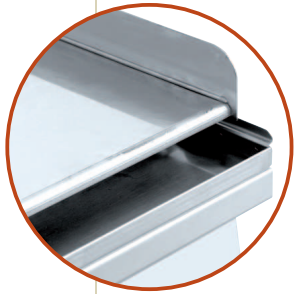
↔ ↗					
		400x420	600x420	800x420	1000x420
Fe. 6 m/m	SERIE 2				
	MOD./COD.	442201P			
	€	101	133	174	255
Fe. 10 m/m	SERIE 5				
	MOD./COD.	440201P			
	€	171	203	249	340
Cr.D 12 m/m	SERIE 8				
	MOD./COD.	444201P			
	€	421	563	739	900

SIMBOLOGÍA

□ SYMBOLOGY □ SIMBOLOGÍA □ SYMBOLE



Largo.
Length. Large Lange.



Fondo.
Width. Profond. Hintergrund.



Alto.
Height. Haut. Stoppen.



Peso.
Weight. Poids. Gewicht.



Capacidad litros.
Litres capacity. Capacite en litres.
Fassungsvermögen Liter.



Dimensiones cuba.
Dim. tank. Dim. cube. Maße Behälter.



Grifo.
Tap. Robinet. Hahn



Soporte Abierto.
Open stand. Support ouvert. Offene Stütze.



Puertas.
Doors. Portes. Türen.



Fuegos gas.
Burners. Feux. Flammen.



Placa eléctrica redonda.
Electric rounded plate. Plaque électrique rond.
Round Kochplatte.



Gastronorm
Gastronorm. Gastronorm. Gastronorm.



Placa.
Plate. Plaque. Platte.



Parrilla.
Grill. Gril. Glasiertes.



Dotación de serie
Standard equipment. L'équipement standard.
Standardausrüstung



Gas
Gas. Gaz. Gas.



Eléctrico
Electric. Électrique. Elektrische.



Precio EUROS
Price in EUROS. Prix en euro. Preis EURO.

1 Kw. Gas = 860 Kcal/h
1 Kcal/h = 1,16 Kw. Gas
1 HP = 746W



CONDICIONES DE VENTA



PRECIOS

Los precios de la presente tarifa son P.V.P. (Impuestos no incluidos - IVA)

FORMAS DE PAGO

En construcciones especiales 30% al pasar el pedido.



CONTADO

Descuento por pago anticipado 2%.

1ª operación: contado al pasar el pedido. Una vez concedido el crédito la forma de pago será 30, 60 días fecha factura.

CRÉDITO

En facturas de hasta 300€, el pago será a 30 días fecha factura.



PORTES EN ESPAÑA

Pagados en Península y Baleares



CARACTERÍSTICAS TÉCNICAS

Como fabricantes nos reservamos el derecho de modificar sin previo aviso las características que constan en este catálogo en beneficio de mejorar nuestros productos.

GARANTÍA

La garantía se concede solamente en los defectos de fabricación quedando excluidos de ella la utilización indebida.



PIEZAS

Dicha garantía es de 12 meses en piezas defectuosas, siendo por cuenta del cliente los portes de ida y vuelta de dichas piezas. Todo material remitido en garantía se facturará y se procederá a su correspondiente abono, una vez remitidas las piezas defectuosas y comprobadas por parte del fabricante.

MANO DE OBRA

El servicio de mano de obra y los desplazamientos son siempre por cuenta del cliente. El fabricante no se hará cargo en ningún caso de ningún tipo o clase de indemnización.



JURISDICCIÓN

Serán únicamente competentes, en caso de litigio, los tribunales de Barcelona.



SALES CONDITIONS



PRICES

The prices in this list are retail prices (EX-WORKS).



PAYMENT CONDITIONS

Irrevocable letter of credit or Swift.



TECHNICAL CHARACTERISTICS

The manufacturer reserves the right to modify the characteristics mentioned in this catalogue to improve the quality of the products, without previous advice.



GUARANTEE

The guarantee only covers manufacturing defects and excludes unauthorized use.

PARTS

The guarantee for defective parts are 12 months. All shipping costs are to be paid by the customer. The manufacturer does not accept any responsibility for any type of compensation.



JURISDICTION

In the event of legal action, the only Courts considered competent are those of Barcelona (Spain).



CONDITIONS DE VENTE



PRIX

Les prix du présent tarif correspondent à des Prix de Vente au Public. [EX-WORKS].



FORME DE PAIEMENT

Lettre de crédit bancaire irrévocable o Virement bancaire.



CARACTERISTIQUES TECHNIQUES

En tant que fabricants, nous nous réservons le droit de modifier sans préavis les caractéristiques indiquées dans le présent catalogue, dans le but d'améliorer nos produits.



GARANTIE

La garantie couvre uniquement les défauts de fabrication, une utilisation incorrecte en étant totalement exclue.

Pieces

Cette garantie est de 12 mois sur les pièces défectueuses, leurs transports d'aller et de retour étant à la charge du client. Le fabricant ne prendra en aucun cas à sa charge aucune indemnité quelle qu'elle soit.



JURISDICTION

En cas de litige, seuls les Tribunaux de Barcelona (Espagne) seront compétents.